



England
netball

SchoolClubLinksGuide

Contents



Page 3	Introduction
Page 4	The 5 Stage Delivery Model
Page 5	Teacher, Coach and Umpire Education
Page 8	Student Development
Page 10	Coaching and Umpiring Support
Page 11	Competition
Page 12	Exit Route
Page 13	Working Example 1
Page 15	Working Example 2
Page 17	Appendix 1 Regional Administrators Contact List
Page 18	Appendix 2 England Netball Player Pathway
Page 19	Appendix 3 Club Action Planning Scheme (CAPS)
Page 20	Appendix 4 England Netball Affiliation Information

Introduction

The England Netball School Clubs Links programme supports the National PE, School Sport and Club Links (PESSCL) strategy which aims to ensure that all children, whatever their circumstances or abilities, should be able to participate and enjoy physical education and sport. By working in partnership with School Sports Partnerships, Clubs, County Sports Partnerships and the Netball infrastructure, England Netball is committed to increasing the number of children participating in clubs from School Sport Partnerships (SSPs) and to increase the number of accredited Netball clubs.

Working in Partnership

England Netball recognises the pressure on the education sector to deliver against National Curriculum targets and outcomes and the growing demand on clubs to ensure they are delivering in a high quality environment. Therefore, the England Netball School Club Link programme has been developed as a 'support tool' for Teachers (primary and secondary), Partnership Development Managers, School Sports Co-ordinators, Competition Managers and Clubs, offering an integrated approach linked to partner outcomes. The programme offers a step by step guide to developing a high quality School Club Link and is supported with resources and examples of best practice.

Using the England Netball School Clubs Links Guide

This England Netball School Clubs Links Guide provides all the information required to create a high quality Netball school club link. The '5 Stage Delivery Model' enables schools and clubs to work together to create their own unique school club link programme by selecting from a wide range of courses, resources and support. However please note that this is only a guide and other creative ideas may be included to suit the needs of your school club link. Through the County Sports Partnership and England Netball Regional Unit, Netball Officers are available to support the development of the programmes. For contact details and further information on the England Netball School Clubs Links programme please visit www.EnglandNetball.co.uk



Teacher, Coach & Umpire Education

Student Development

Coaching & Umpiring Support

Competition

Exit Route

The 5 Stage Delivery Model Outcome = Partnership Development Managers Outcome

Outcome - 1 & 3	Outcome - 2 & 6	Outcome - 1, 2 & 3	Outcome - 4	Outcome - 7
An Introduction to Long Term Athlete Development	Young Netball Organiser Course (14 - 18 years)	Within Curriculum	Key Stage 2, 7-9years Multi-Skills Festivals	Establish Out of School Hours Club
Netball for Players aged 7-11years	Netball UKCC Level 1 Assistant Coach (from 16 years)	Out of School Hours Learning	Key Stage 2, 9-11years High 5 Netball Festivals	Develop Local Feeder Club
High 5 Awareness Workshop	Beginners Umpire Course (from 12 years)	Young Netball Organisers Support Club Coach/Umpire and/or Primary Teacher	Key Stage 3, 11-12years 7 aside Leagues	
Coaching Players aged 12-16years	Table Officials Award (from 16 years)	Teachers and/ or Club Coach/Umpire to Mentor Young Netball Organisers	Key stage 3 & 4, 12-16years Inter & Intra School Leagues	Players into Existing Local Club
Umpiring Players aged 12-16years	Youth Umpire Award (13 - 18 years)	Skills Awards		
Netball UKCC Level 1 Assistant Coach and Level 2 Coach	Step into Sport Scheme (14 - 19 years)			
Beginners Umpire Course and Europe 'C' Umpire Award Course and Assessment				
Performance Standard Workshop				
A Guide to Mentoring				
Analysing Your Coaching				
Duty of Care				

Teacher, Coach & Umpire Education

Any activity that supports the development of knowledge and skills of teaching staff.

Course	Aim	Outcome	Eligibility and Experience	Course Delivery
<p>An Introduction to Long Term Athlete Development (LTAD)</p> <p>ScJK Workshop</p>	<p>To enable attendees to understand the key concepts of LTAD and what it means to them and their practice.</p>	<ul style="list-style-type: none"> Identify and recognise the reasons for adopting LTAD Identify and recognise the concepts and key principles of LTAD Recognise and respond to the implication for coaches and coaching Identify appropriate action to integrate LTAD into their coaching 	<p>Over 16years</p>	<p>Visit Sports Coach UK website www.sportsoachuk.org</p>
<p>Netball for Players aged 7-11 years Course</p>	<p>To provide ideas for teachers and coaches working both within and outside of the curriculum with players aged 7-11years. Introduce rules and application of rules to High 5.</p>	<ul style="list-style-type: none"> Focus on High 5 Netball To orientate teachers to meet the national key stages of the curriculum <p>This can be used to train teachers in High 5 Netball and potentially bridge the gap between primary school Netball and secondary school Netball.</p>	<p>Primary Teachers, AOTT's, Parents, Coaches working with children aged 7-11years. No Netball knowledge required.</p>	<p>Duration - 6 hours can be delivered 3 x 2hr sessions Resources cost - £8 (teachers) £10 (Non teachers) Tutor Cost - £120. Travel expenses 30p per mile Tutor Requirements - England Netball accredited tutors</p>
<p>High 5 Awareness Workshop</p>	<p>To support teachers/coaches to understand and teach High 5 Netball</p>	<ul style="list-style-type: none"> Be familiar with the philosophy and principles behind High 5 Netball Be able to identify and teach/coach basic Netball skills used in High 5 Netball Be able to umpire the game of High 5 Netball 	<p>Knowledge of teaching/coaching Netball.</p>	<p>Duration - 2hrs Resource cost - £7 (order Teacher Student Pack) Tutor cost - contact your Regional Administrator Tutor requirements - contact your Regional Administrator</p>

Course	Aim	Outcome	Eligibility and Experience	Course Delivery
Coaching Players aged 12-16years Course	To provide teachers working with Key Stage 3 and 4 pupils with extra resources and support to enable them to teach within the curriculum and to improve team performance.	<ul style="list-style-type: none"> To identify and apply the basic principles of play To identify the elements involved in a progressive practice and to have the knowledge to develop their own To plan schemes and units of work which incorporates Netball specific tasks To teach and develop elements of team play To identify appropriate teaching material to support the delivery of a GCSE Netball module 	Teacher working at Key Stage 3 and 4, who wish to update their knowledge. A basic knowledge of the rules.	<p>Duration - 6 hours</p> <p>Resource costs - £11</p> <p>Tutor costs - £120 plus travel expenses of 30p per mile</p> <p>Tutor requirements - contact your Regional Administrator</p>
Umpiring Players aged 12-16years Course	To provide teachers working with Key Stage 3 and 4 pupils with the opportunity to update their knowledge of the rules and their application as for 'C' Award.	<ul style="list-style-type: none"> To identify and apply personal skills of an umpire To understand the rules of the game To be able to control the game by penalising correctly obvious infringements of the rules Correct use of whistle, voice and terminology Positioning and movement Appearance and manner Keep correct scorecard and call the score 	Teachers working at Key Stage 3 and 4, who wish to update their knowledge. A basic knowledge of the rules.	<p>Duration - 6 hours</p> <p>Resource cost - £8.50 (order 'C' Awards resource)</p> <p>Tutor cost - £120 plus travel expenses of 30p per mile</p> <p>Tutor requirements - contact your Regional Administrator</p>
Netball UKCC Level 1 Assistant Coach and Level 2 Coach	<p>Netball UKCC Level 1 Assistant Coach Assist more qualified coaches, delivering aspects of coaching sessions, normally under direct supervision.</p> <p>Netball UKCC Level 2 Coach Prepare for, deliver and review coaching session(s). Level 2 is the first qualification where England Netball would encourage coaches to be coaching independently or as part of a coaching team as opposed to at an assistant level.</p> <p>More details will be available in summer 2006 and the course will be delivered from September 2006. For further information please contact your Regional Administrator or visit www.netballukcc.co.uk</p>			

Course	Aim	Outcome	Eligibility and Experience	Course Delivery
Beginners Umpire Course	To introduce rudiments of umpiring Netball at an inexperienced level whether at school or club.	<ul style="list-style-type: none"> To gain basic knowledge of rules Can identify obvious infringements of rules Apply correct use of terminology, and correct positioning 	From 12 years. England Netball Affiliated.	<p>Duration - 4 hours</p> <p>Resource cost - £7</p> <p>Tutor cost - £60. Travel expenses 30p per mile</p> <p>Tutor requirements - contact your Regional Administrator</p>
Netball Europe 'C' Umpire Award Course and Assessment	To prepare umpires with the knowledge of the rules and umpire competencies to umpire at average adult club level.	<ul style="list-style-type: none"> To be able to apply the rules and control the game by penalising correctly obvious infringements Correct use of voice, whistle and terminology; positioning and movement; keeping a scorecard 	From 14 years. Umpiring experience at league or school level. Affiliated to England Netball.	<p>Duration - 6hours</p> <p>Resource Cost - £8.50</p> <p>Tutor Cost - £120.00 plus expenses @ 30p per mile</p> <p>Tutor requirements - contact Regional Administrator</p>
A Guide to Mentoring Sports Coaches SoJUK Workshop	This workshop will help you as a mentor to support coaches' learning and focus on how learning occurs.	<ul style="list-style-type: none"> Identify your role as a mentor Develop your mentoring profile Increase the effectiveness of your mentoring relationship by providing practical mentoring skills Design a mentoring programme that best suits the needs of your sport and the levels of coaching 	From 16 years.	<p>Visit Sports Coach UK website www.sportsoachuk.org</p>
Performance Standard Workshop	To provide coaches and teacher with the knowledge and understanding of the characteristics of a potentially talented athlete.	<ul style="list-style-type: none"> Attendees will be able to nominate players for consideration within Satellite and County Academy Programmes or within a Regional Screening Programme for Regional Talent Development Programmes and Potential Talent Camps 	Level 1 coach or teacher working with young netball players.	<p>Duration - 6 hours</p> <p>Resource cost - £6.00</p> <p>Tutor cost - £120 plus travel expenses of 30p per mile</p> <p>Tutor requirement - contact your Regional Administrator</p>

Course	Aim	Outcome	Eligibility and Experience	Course Delivery
Analysing Your Coaching scUK Workshop	To find improvements in your coaching practice. Discover methods of analysing your own coaching performance and identify areas for development. Learn how to develop and implement an action plan to enhance your coaching.	<ul style="list-style-type: none"> Analyse your own performance against a checklist to identify areas of strengths and weaknesses Recognise the different behaviours you exhibit in your coaching Devise and implement an action plan to change aspects of your own coaching behaviour where required 		Visit Sports Coach UK website www.sportiscoachuk.org
Duty of Care	To provide an awareness of the issues surrounding Duty of Care and offer guidelines and action plans.	<ul style="list-style-type: none"> To understand the principles of Duty of Care To be aware of the wider context of child protection, and appropriate action if you have suspicions that child abuse has taken place To be aware of England Netball policies and procedures To prepare an action plan to implement Duty of Care policies and procedures 	From 18 years. Involved in delivering Netball.	<p>Duration - 5 hours</p> <p>Resource costs - £8</p> <p>Tutor costs - £150 plus travel expenses of 30p per mile</p> <p>Tutor requirements - contact your Regional Administrator</p>



Student Development

Any activity that supports the development of knowledge and skills of students.

Course	Aim	Outcome	Eligibility and Experience	Course Delivery
Young Netball Organiser Course	To offer young people aged 14-18years the opportunity to take the first step onto the coaching, officiating or administration ladder. It prepares them to organise quality, enjoyable purposeful sessions for 7-11years.	<ul style="list-style-type: none"> Plan and deliver a safe session Identify and teach basic skills Progress basic skills into a small game situation Develop High 5 Netball Introduce appropriate rules within the session Organise a mini tournament or fun day <p>This course can act as a bolt on course to the JSLA and CSLA awards which link to Step into Sport young volunteers.</p>	Young people aged 14-18years. No Netball knowledge required.	<p>Options;</p> <p>1. A school teacher can deliver (if they have experience in coaching/teaching Netball). School to purchase a starter pack which includes the teacher resource and 15 pupil resources.</p> <p>Duration - 6 hours</p> <p>Resource cost - £125 Starter pack with 15 resources. Extra recourses £8 per person.</p> <p>Tutor cost - N/A</p> <p>Tutor requirements - Teacher delivery</p> <p>2. If you do not have a teacher able to deliver the course an England Netball accredited tutor can deliver.</p> <p>Duration - 6 hours</p> <p>Resource cost - £8 per person.</p> <p>Tutor cost - £120. Travel expenses 30p per mile</p> <p>Tutor requirements - England Netball accredited tutor</p>
Netball UKCC Level 1 Assistant Coach				See Teacher Education section. More details will be available in summer 2006 and the course will be delivered from September 2006. For further information please contact your Regional Administrator or visit www.netballukcc.co.uk
Beginners Umpire Course				See Teacher Education section.
Table Officials Award				Minimum age 16 years but we can facilitate courses for younger age groups if requested. Available from September 2006. For further information contact your Regional Administrator or visit www.englishnetball.co.uk
Youth Umpire Award				13-18 year target group. Available from September 2006. For further information contact your Regional Administrator or visit www.englishnetball.co.uk
Step into Sport Scheme				Step into Sport focuses on young people aged 14-19 years, giving them opportunities to become involved in sports leadership and volunteering and encouraging them to continue this into later life. The programme is funded by the Department of Culture, Media and Sport (DCMS) as part of the national Physical Education School Sport and Club Links (PESSCL) strategy.

<p>Coaching & Umpiring Support</p> <p>To provide teaching staff with the technical Netball specific support by having a club coach/umpire and/or Young Netball Organisers (YNOs) support High 5 / Netball delivery. This can be achieved in curriculum time or via Out of School Hours Learning (OSHL).</p>	<p>Within Curriculum</p> <p>The coaching/umpiring programme can be modified to suit your School Sport Partnership needs i.e. flexibility with duration/regularity of support. Club coaches/umpires to support and enhance the teachers' delivery of Netball within the curriculum time.</p>
<p>Out of School Hours Learning</p>	<p>Club coach/umpire to support and enhance the teachers delivery of Netball through Out of School Hours Learning.</p>
<p>Young Netball Organisers Support Club Coach/Umpire and/or Primary Teacher</p>	<p>A YNO will have a practical knowledge of umpiring, coaching and tournament facilitation therefore can support the primary teachers with the delivery of High 5. The YNO can use this experience to complete their hours of volunteering if involved in a volunteering programme.</p>
<p>Teachers and/ or Club Coach/Umpire to Mentor Young Netball Organisers</p>	<p>The teachers and/or club coach/umpire can act as a mentor to the YNOs.</p>
<p>Skills Awards</p>	<p>An updated version of Skills Awards will be available from September 2006. The awards have been revised to include the Fundamental movement skills and to reflect the Long Term Athlete Development Programme. Skills Awards are an ideal assessment tool to be used by teacher to monitor progress of players. Skills Awards range from Key Stage 1 to Key Stage 3 and can be delivered both in the curriculum and in a club environment.</p>



Competition

To provide high quality competition at the appropriate level through physical education and school sport for all young people.

KEY STAGE 2: 7 - 9 years

- Multi-skills festivals (termly)
- Theme based with generic skills to achieve Performance standards
- Primary school clusters with flexible & moveable venues according to local need

SCHEDULE: termly

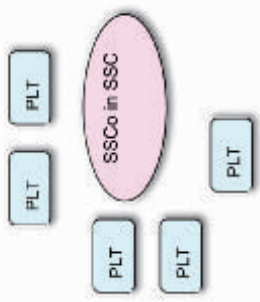

KEY STAGE 2: 9-11 years

- Multisport
- High 5 Netball, single sex or mixed
- Festival or league competition at secondary school site (flexible)
- Coaching & competition with emphasis on participation
- Players do not have to enter as part of school team
- Important for all to participate not 'best boys' who play in all teams sent to win

SCHEDULE: Half-termly between September and April with one held in an indoor venue. Festivals to be staffed by students in Secondary school having completed Y10, Junior Umpire award or CSLA

KEY STAGE 3/4

Level 1

- Participation for all players to enter, not just school team
- Y17, 8 + 9, 10 + 11
- Competitions within SSP

Level 2

Identified athletes to represent SSP against other SSPs in County/Area

Level 3

Identified athletes to represent County/Area SSPs in Regional Competition

Key	
SSCo	- School Sports Coordinator
SSC	- School Sports College
PLT	- Primary Link Teacher
PDM	- Partnership Development Manager
CM	- Competition Manager
SSPs	- School Sports Partnerships

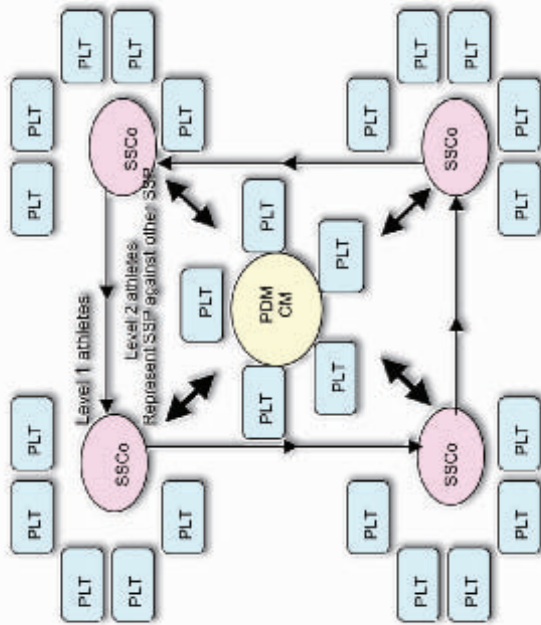

Represent County/Area SSPs in regional competition

Exit Route

To provide players with Out of School Hours coaching to further develop their skills and provide the new opportunities for club competition.

Establish Outside of School Hours Club

Delivered by a teacher an/or club coach with support from YNOs and promoted at coaching sessions and festivals/competition. The after school club should be established at a primary/secondary school site.

Develop Local Feeder Club

A feeder club may be created as a branch of an existing local club. Club coaches and umpires can support the development of a feeder club through coaching, umpiring and mentoring of new coaches/umpires/YNOs. The identification and specific role of a feeder club/s should be decided by all partners (SSP, Netball Development Officer and the local club(s) etc) and integrated into local plans. It is important that the club is working towards England Netball Club Action Planning Scheme (CAPS) as this provides a quality environment with procedures in place for young people.

Players into Existing Local Club

From competitions/ festivals, or skills days the school should actively advertise any local clubs who have achieved CAPS or who are actively working towards CAPS to ensure the players have the option of accessing more training in a quality environment. Clubs can provide players with increased competitions via local leagues



**WORKING EXAMPLE 1
PARTNERSHIP DEVELOPMENT MANAGER (PDM)**

Teacher, Coach & Umpire Education

Outcome - 1 & 3

Netball for players aged 7-11years Workshop

Student Development

Outcome - 2 & 6

Young Netball Organiser Course

Beginners Umpire Course

Coaching & Umpiring Support

Outcome - 1, 2 & 3

Young Netball Organisers Support Club Coach/Umpire and/or Primary Teacher

Teachers and/ or Club Coach / Umpire to Mentor Young Netball Organisers

Skills Awards

Competition

Outcome - 4

Key Stage 2, 9-11years High 5 Netball Festivals

Exit Route

Outcome - 7

Players into Existing Local Club

KEY: PDM



Description of activity that relates to working example 1 (highlighted boxes)

Club: Capricorn Netball Club

SSP: Haydock School Sports Partnership and Sutton School Sports Partnership

Summary

In order to further develop Netball locally and provide competition at the appropriate levels for school pupils the schools and club recognised the need to increase the Netball skills of teachers and support young people in gaining Netball qualifications. A meeting was held with a club representative, the Partnership Development Manager's and the County Netball Development Officer and the following project was agreed.

Teacher, Coach & Umpire Education

As a means of increasing the knowledge and skills of the teachers to support and sustain the development of High 5 Netball in both SSPs a **Netball for Players aged 7-11years Workshop** was held at the local Specialist Sports College.

Student Development

Both SSPs held a **Young Netball Organiser Course** for students which linked to the Step in to Sport programme. A **Beginners Umpire Course** was also held for teachers, students and club volunteers. In addition, students at Rainhill School (specialist in Media and Arts) produced a club handbook and flyer as a school based project.

Coaching & Umpiring Programme

The **Young Netball Organisers completed a 6 week programme** where they worked with the primary schools to deliver an hour of High 5 Netball activity in after school clubs. The club also ran a **skills taster session** for the feeder secondary schools, targeting schools they had yet to establish links with. The teachers and club coaches **mentored** the YNOs on the coaching programme, Skills Day and Festival.

Competition

The YNOs supported the St Helens Sports Development Officer in the organisation and delivery of the **High 5 Festival for Key Stage 2, 9-11years**.

Exit Route

As a result of the programme ten students from Rainhill, Sutton, St Cuthbert's, Broadway and St Augustine schools attended a **Skills Day** at Capricorn Netball Club and went on to join the club as players and volunteers.

WORKING EXAMPLE 2

PARTNERSHIP DEVELOPMENT MANAGER (PDM) and Competition Manager (CM)

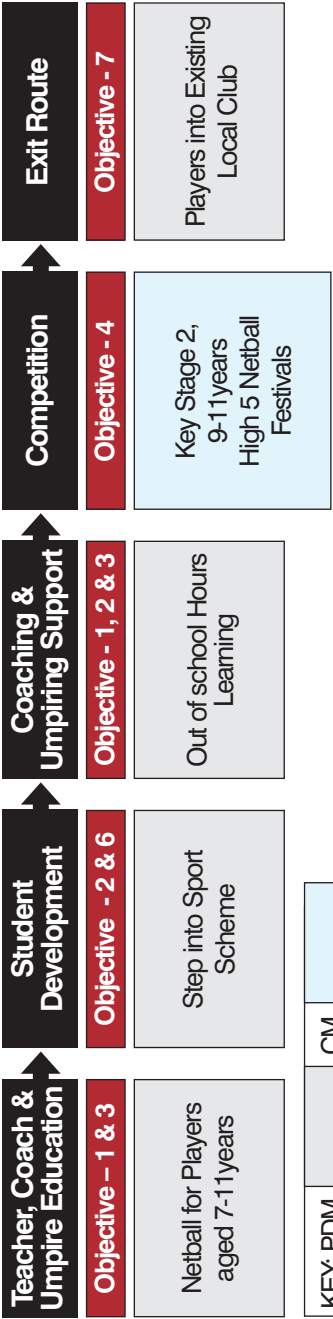

KEY: PDM CM



Description of activity that relates to working example 2 (highlighted boxes)

Club:	Fareham Fireflies Junior Netball Club
School Sports Partnership (SSP):	Henry Cort, Fareham
County Sports Partnership (CSP):	Sport Hampshire & IOW

Summary

As an School Sports Partnership involved in the pilot phase of the School Competition Manager programme Henry Cort SSP and all the partners wanted to ensure that school competition was linked into a cohesive and single vision of Netball delivery to young people in Fareham. Therefore all partners worked together to develop a school club project which increased Netball specific knowledge of teachers, developed a competition programme in line with the competition framework and appropriate to the age group of the players and established schools club links.

Teacher, Coach & Umpire Development

Netball for players aged 7-11years Workshop was co-ordinated by the Competition Manager and Netball Development Officer to provide local teachers and Adults Other Than Teachers (AOTT's) an opportunity to learn and ask questions about High 5 Netball.

Student Development

The students involved in the project were part of the **Step into Sport Scheme** and volunteered to support activity as part of their volunteering hours.

Coaching & Umpiring Programme

The club coaches volunteered time to assist at the **Out of School Hours** Netball sessions, acting as a coaching support mechanism/mentor to teachers.

Competition

The Competition Manager co-ordinated the festivals and tournaments and also ensured all club publicity was distributed to young people via the School Sports Co-ordinators and Primary Link Teachers. The Step into Sport students, supported by the teachers and Partnership Development Manager umpired at the festivals and tournaments. Fareham Fireflies produced flyers and posters advertising their club training details and distributed these to the players attending the festivals and tournament. These were also displayed on school PE notice boards.

Exit Route

Through this partnership working, the schools had a direct link with the existing club ensuring exit routes for school players are in place.

Regional Administrator Contact Details - Appendix 1

Region	Address	Tel / Fax	Email
North West Regional Administrator	University of Chester, Warrington Campus, Crab Lane, Warrington, Cheshire WA2 0DB	Tel: 01925 534393	northwest@englandnetball.co.uk
North East Regional Administrator	House of Sport, University of Durham, South End House, South Road, Durham DH1 3TG	Tel: 0191 3347223 Fax: 0191 3347201	northeast@englandnetball.co.uk
Yorkshire and Humberside Regional Administrator	Netball Centre, English Institute of Sport – Sheffield, Coleridge Road, Sheffield S9 5DA	Tel: 0114 2235697	yorksandhumber@englandnetball.co.uk
West Midlands Regional Administrator	Greater Warwickshire Sport, University of Warwick, Westwood Campus, Coventry CV4 7AL	Tel: 02476 575841	westmidlands@englandnetball.co.uk
East Midlands Regional Administrator	The Netball Centre, Loughborough University, Leicestershire LE11 3TU	Tel: 01509 226753	eastmidlands@englandnetball.co.uk
East Regional Administrator	Hethersett Old Hall School, Old Norwich Road, Norwich, Norfolk NR9 3DW	Tel: 01603 811362	east@englandnetball.co.uk
London and South East Regional Administrator	University of Greenwich at Medway, Centre for Sport and Exercise Sciences, Chatham Maritime ME4 4TB	Tel: 0208 3319873	londonandsoutheast@englandnetball.co.uk
South Regional Administrator	Bisham Abbey National Sports Centre Bisham, Nr Marlow, Buckinghamshire SL7 1RT	Tel: 01628 477090	south@englandnetball.co.uk
South West Regional Administrator	National Netball Centre, South West Region, The University of Bath, Sports Training Village, Claverton Down, Bath BA2 7AY	Tel: 01225 383774	southwest@englandnetball.co.uk

Player Pathway - Appendix 2

CORE SERVICES :- Facilities, Workforce Development, (Coaching, Officiating, Volunteering,) Competition, Sport Science, Commercial (These services will be relevant to individual needs)

- National Athletes
- Participation
- LTAD
- Core Services for all
- Talent Development

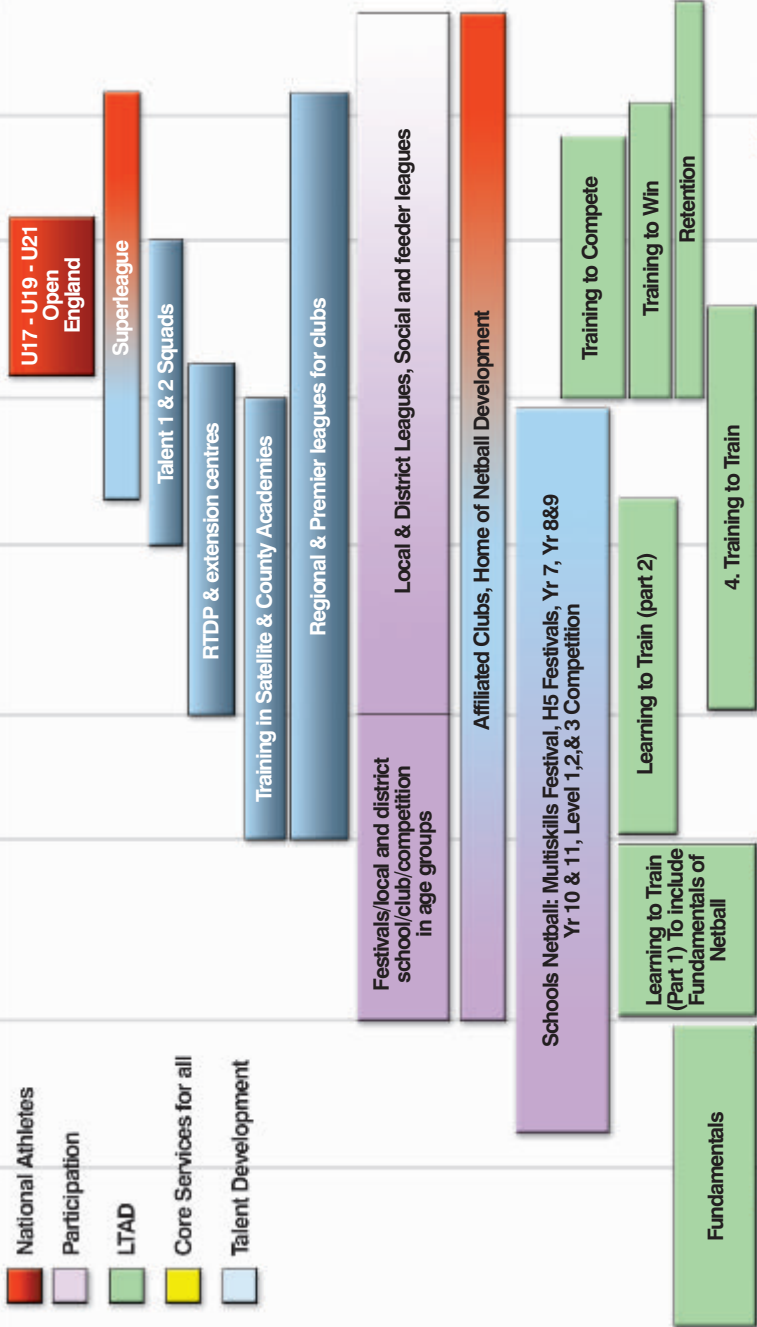

Age.....5years.....9years.....11years.....14years.....15years.....16years.....19years.....

Club Action Planning Scheme (CAPS)

England Netball has a club accreditation scheme known as CAPS which is part of the Sport England Clubmark Scheme. There are three levels, Bronze (Clubmark), Silver and Gold.

What is the CAPS Netball scheme?

The scheme has been introduced to provide a Netball club structure, which has the player as its primary focus. It will provide an overall view of an individual club within the 'big picture' of the England Netball structure, and will help forge stronger links between England Netball centrally and its clubs. The scheme will aim to establish the 'club' as the basic unit for player development. By working through the scheme it will assist your Netball club in providing the best quality service for your members by creating an appropriately qualified 'work force' of coaches, umpires and administrators.

Who can apply?

Netball clubs, youth clubs, young persons groups, colleges, universities, secondary, middle, junior and primary schools all of whom must be affiliated to the England Netball. Where a school or college applies, it must be on behalf of a school club that meets regularly.

Why should a Club be involved?

CAPS is an excellent way to enable clubs to increase member numbers and improve the standard of activity in all areas including playing, coaching, umpiring or administrating.

The accreditation signifies that parents / carers and players may expect a club which has specified minimum quality standards for the playing of Netball.

The England Netball CAPS scheme is part of the Sport England Clubmark scheme and CAPS encompasses all the minimum operating standards laid down by Clubmark.

CAPS offers:

- Increased exposure and publicity through Sport England, England Netball and other agencies
- An increased possibility of securing funds for local incentives e.g. reduced facility costs
- The ability to attract more members – players, coaches and umpires
- A clear development pathway for members – current and potential
- Stronger links to the local community
- CAPS and Clubmark certificate and use of logo's on club kit
- Discounts on merchandise
- Additional County and Regional incentives

SchoolClubLinksGuide

England Netball Affiliation Benefits

Six issues per year of Netball Magazine – an informative and vibrant Netball and lifestyle journal, of interest to participants and non-Netballers alike.

Civil Liability and Personal Accident insurance.

Access to England Netball courses, awards and events.

Entry to EN competitions – a player-centred, exciting, high-quality structure which identifies and nurtures talent, and where participants are encouraged to become the best they can be at their level.

Discounts on Netball merchandise and test series tickets, as well as an increasing range of exclusive offers from EN partners.

Information, advice and support direct from our County, Regional and National networks.

Support from England Netball qualified Coaches and Umpires.

The nominated Club representative receives a copy of the Association's Annual Report, and Handbook containing a comprehensive list of contacts, and general Netball guidance.

Access to our Clubs Action Planning Scheme (CAPS). Linked to Sport England's Clubmark programme, CAPS helps your Club to develop in many areas, such as: attracting and encouraging new players and volunteers; coaching and competition; club management / administration; applying for funding.

A Club representative is entitled to vote at General Meetings.

Equity and Welfare benefits for Clubs include access to child protection, equal opportunities and sports equity advice and resources.

For further information on schools affiliation or to download an affiliation form please visit our website www.EnglandNetball.co.uk

or contact England Netball Affiliations:

T: +44 (0)1462 442344 F: +44 (0)1462 442343

E: affiliations@EnglandNetball.co.uk